

Crane Kit Enquiry Form

Please complete this form with as much information as possible. You can either complete this form directly and return to us by selecting the submit button at the bottom of the page. Or print out and Fax to 01454 317999. We will endeavour to return your quote as quickly as possible. If you have any questions or you require any further information please contact us on 01454 332270.

Contact Details

Name:		Phone:	
Company Name:		Fax:	
Address:		Mobile:	
		Email:	

Crane Kits Details

Control:	<input type="checkbox"/> Bridge Crane / Monorail	<input type="checkbox"/> Light Crane System
-----------------	--	---

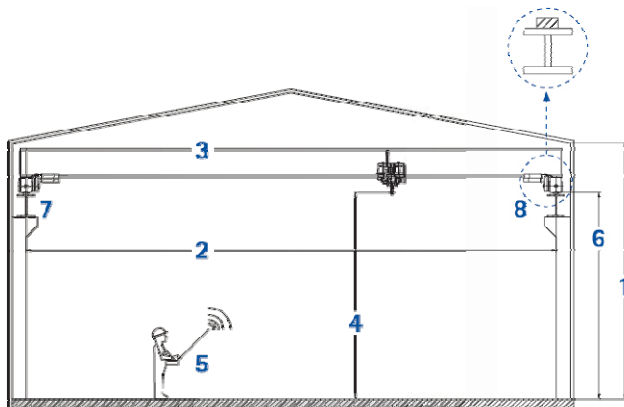

1. Building Height:		mm
2. Crane Span/ Monorail Length:		mm
3. Beam Width:		mm
4. Lifting Height:		mm
5. Remote Control:	<input type="checkbox"/> Yes	<input type="checkbox"/> No
6. Top Edge Height of Crane Rail:		mm
7. Runway Rail Length:		mm
8. Runway Rail:		mm

Hoist:	<input type="checkbox"/> Chain Hoist	<input type="checkbox"/> Wire Rope Hoist
Crane Type:	<input type="checkbox"/> Single Girder Crane _____swl kg	<input type="checkbox"/> Double Girder Crane _____swl kg
	<input type="checkbox"/> Underslung Crane _____swl kg	<input type="checkbox"/> Monorail _____swl kg
RHC to Quote for Supply of Beam:	<input type="checkbox"/> Yes	<input type="checkbox"/> No
Power Supply:	400 V / 50 Hz	_____V / _____HZ
Control Voltage:	48V	<input type="checkbox"/> 115V <input type="checkbox"/> 230V
Power Feeding Line:	<input type="checkbox"/> Flat Cable	<input type="checkbox"/> Energy Chain (remote control needed)
Duty Group:	<input type="checkbox"/> Fem: 1Bm (M3)	<input type="checkbox"/> 1Am (M4)
	<input type="checkbox"/> 2m (M5)	<input type="checkbox"/> 3m (M6)
Conditions:	<input type="checkbox"/> Outdoors under Roof	<input type="checkbox"/> Outdoors <input type="checkbox"/> Indoor
Ambient Temperature:	<input type="checkbox"/> +5°C to +40°C	<input type="checkbox"/> Up to +40°C <input type="checkbox"/> +55°C
	<input type="checkbox"/> From -20°C	<input type="checkbox"/> -10°C <input type="checkbox"/> 0°C
Explosion Proofed:	<input type="checkbox"/> Gas Zone 1 IIB T4	<input type="checkbox"/> Gas Zone 1 IIC T4 <input type="checkbox"/> Gas Zone 1 IIB T3
	<input type="checkbox"/> Gas Zone 1 IIB T3	<input type="checkbox"/> Dust Zone 21 IP65 T+135°C <input type="checkbox"/> Dust Zone 22 IP55 T+155°C
Additions for Light Crane System:	<input type="checkbox"/> ProfileMaster	<input type="checkbox"/> LIGHTster
	<input type="checkbox"/> Suspension Distance _____mm	<input type="checkbox"/> Suspension Type _____

**Addition
Information /
Requirements /
Sketch of Project:**